

RFD-200

Insulation Resistance Meter



Vanguard Instruments Company
www.vanguard-instruments.com



RFD-200™ Series 2

The RFD-200 S2 is a portable relay test set that delivers performance verification testing of electromechanical, electronic, and microprocessor-based protective relays in their operating installations. The RFD-200 S2 is a rugged test set suitable for testing a variety of protection relays operated in both indoor and outdoor environments. The unit's ergonomic design and intuitive control panel layout make it ideal for first-time users who have little or no training.

AC Current Source

An AC current source with three outputs (10A, 40A, and 100A) provides test current to relays. The current source output can be programmed to synchronize with the RFD-200 S2's timer. After a test is completed, the test current reading is latched and displayed on the LCD screen. This feature reduces the possibility of overheating the relay coils.

Built-in Power Resistors

The RFD-200 S2 features built-in power resistors for fine current adjustment.

AC Voltage Source

An AC voltage source is available for testing relays up to 250 Vac. The AC voltage source output can be programmed to synchronize with the RFD200 S2's timer.

DC Voltage Source

A 0 – 300 Vdc voltage source is also available. The DC voltage source can also be programmed to synchronize with the RFD-200 S2's timer.

Built-in Digital Timer

The RFD-200 S2's digital timer features independent start and stop trigger inputs

Ergonomic Design



designed to measure the time between event transitions and to display the elapsed time in both milli-seconds and cycles. The RFD-200 S2's timer has three different trigger inputs – Internal Trigger, Dry-Contact, or Wet-Contact. The Internal Trigger can start or stop the timer by sensing the application or removal of the unit's voltage or current source. The Dry-Contact can trigger the timer by detecting a change in state of the dry-contact input. Similarly, the Wet-Contact can trigger the timer by detecting a change in state of the voltage input. Thus, the three inputs can trigger the timer by the presence or removal of the unit's voltage or current source or by changes in voltage or current states.

Auxiliary AC/DC Power Supplies

The RFD-200 S2 provides three power supplies (24 Vdc, 124 Vdc and 240 Vac) for powering solid-state or microprocessor-based relays.

RFD-200 S2 Ampere Meters

The test current is displayed on the unit's back-lit LCD screen that is viewable in both bright sunlight and low-light levels. The current measuring range is from 0.00 to 250 A. A second ampere meter is also available and can be used to read an external current input. The external current input is rated at 6 A max and is protected by a circuit-breaker.

RFD-200 S2 Volt Meter

One volt meter input (0 to 600 V input range) is available on the RFD-200 S2.

FEATURES AT A GLANCE

- Built-in digital timer displays contact time in both cycles and milli-seconds
- Provides variable AC current source (up to 250 Amps)
- Provides variable AC voltage source (up to 240 Vac)
- Provides variable DC voltage source (up to 300 Vdc)
- Auxiliary AC/DC power supplies for powering solid-state or microprocessor based relays
- Back-lit LCD screen (20 characters by 4 lines) viewable in bright sunlight and low-light levels
- Tests current transformer excitation
- Tests transformer turns-ratio

Test a Wide Variety of Relays in their Outdoor Environments

and Intuitive Controls Make Performance Verification Testing *a Breeze*

SPECIFICATIONS

| | |
|----------------------------------|--|
| TYPE | Portable relay test set |
| INPUT POWER | 100 – 120 Vac or 200 – 240 Vac (factory pre-set), 50/60 Hz |
| PHYSICAL SPECIFICATIONS | 16.8"W x 12.6"H x 12"D (42.7 cm x 32.0 cm x 30.5 cm); Weight: 35 lbs (15.9 kg) |
| AMPERE METER INPUT RANGES | Internal input range: 0 – 250 A; Accuracy: 2% of reading \pm 10 mA, External AC input range: 0 – 6A; Accuracy: 1% of reading \pm 10mA; External DC input range: 0 – 6A; Accuracy: 0.5% of reading \pm 1 count Measurement Method: True RMS for AC |
| VOLT METER INPUT RANGE | 0 – 600.0V; AC accuracy: 1% of reading \pm 1 count; DC accuracy 0.5% of reading \pm 1 count Measurement Method: True RMS for AC |
| AUXILIARY POWER SUPPLIES | 24 Vdc @ 1 A, 124 Vdc @ 0.25 A, 240 Vac @ 0.125 A |
| SAFETY | Designed to meet IEC61010 (1995), UL61010A-1, CSA-C22.2 standards |
| ENVIRONMENT | Operating: -10°C to 50° C (15°F to +122° F); Storage: -30° C to 70° C (-22°F to +158° F) |
| HUMIDITY | 90% RH @ 40°C (104°F) non-condensing |
| ALTITUDE | 2,000m (6,562 ft) to full safety specifications |
| OPTIONS | Transportation case |
| WARRANTY | One year on parts and labor |

| AC Current Output | | | | |
|--------------------------|------------------------|---------------------|---------------------|--------------------------|
| <i>Range</i> | <i>No-Load Voltage</i> | <i>Load Voltage</i> | <i>Load Current</i> | <i>Load/Unload Times</i> |
| 10 A | 90 Vac | 75 Vac | 10 A | 2 min / 15 min |
| 40 A | 25 Vac | 20 Vac | 40 A | 1 min / 15 min |
| 100 A | 10 Vac | 7.25 Vac | 100 A | 1 min / 15 min |
| 100 A | 10 Vac | 3 Vac | 250 A | 1 sec / 5 min |
| AC Voltage Output | | | | |
| <i>Range</i> | <i>No-Load Voltage</i> | <i>Load Voltage</i> | <i>Load Current</i> | <i>Load/Unload Times</i> |
| 250 Vac | 260 Vac | 240 Vac | 3 A | 10min / 45 min |
| DC Voltage Output | | | | |
| <i>Range</i> | <i>No-Load Voltage</i> | <i>Load Voltage</i> | <i>Load Current</i> | <i>Load/Unload Times</i> |
| 300 Vdc | 300 Vac | 250 Vdc | 2 A | 10 min / 45 min |

| RFD-200 Timer Second Display In seconds and cycles (50/60 Hz programmable) | | |
|---|-------------------|---------------------------|
| <i>Range</i> | <i>Resolution</i> | <i>Accuracy</i> |
| 0 to 9.999 sec | 1 ms | \pm (1 ms + 0.01%) |
| 10.00 to 99.99 sec | 10 ms | \pm (10 ms + 0.01%) |
| 100.0 to 999.999 sec | 100 ms | \pm (100 ms + 0.01%) |
| Timer Cycles Display | | |
| <i>Range</i> | <i>Resolution</i> | <i>Accuracy</i> |
| 0 to 9.999 cycles | 0.1 cycles | \pm (0.1 cycle + 0.01%) |
| 1,000 to 49,999 cycles / 50 Hz | 1 cycle | \pm (1 cycle + 0.01%) |

Note: The above specifications are valid at nominal voltage and ambient temperature of +25°C (+77°F). Specifications are subject to change without notice.

Easy Testing of Electro-mechanical, Electronic

RFD-200 S2 Connections

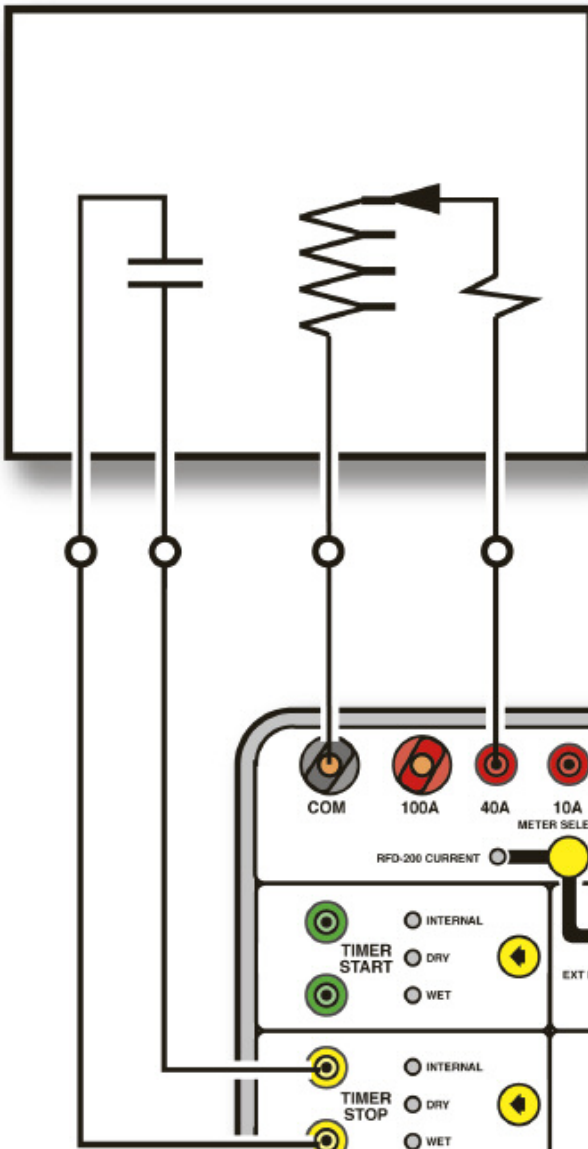

- Current Source (1)
- Built-in Power Resistor (3)
- Back-lit LCD Screen (20 characters by 4 lines)
- External Input Current (2)
- Voltage Input (4)
- Timer Start (14)
- Test Completed LED (9)
- Timer Stop (13)
- Control Mode LED (11)
- RS-232C Interface (5)
- Control Mode Selection (10)
- Output Control Knob (6)
- Auxiliary Power On/Off (7)
- Auxiliary Power Selector (8)
- Auxiliary Power Connectors (12)

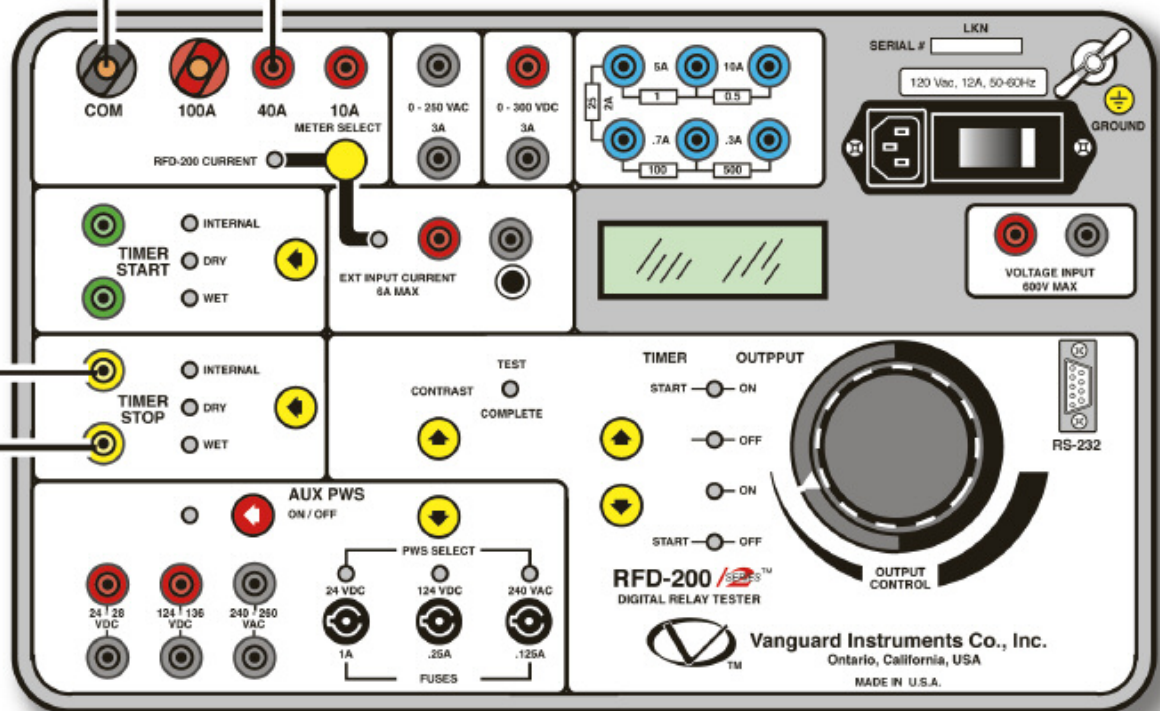

Test a Wide Variety of Relays in their Outdoor Environments

& Microprocessor Based Protective Relays

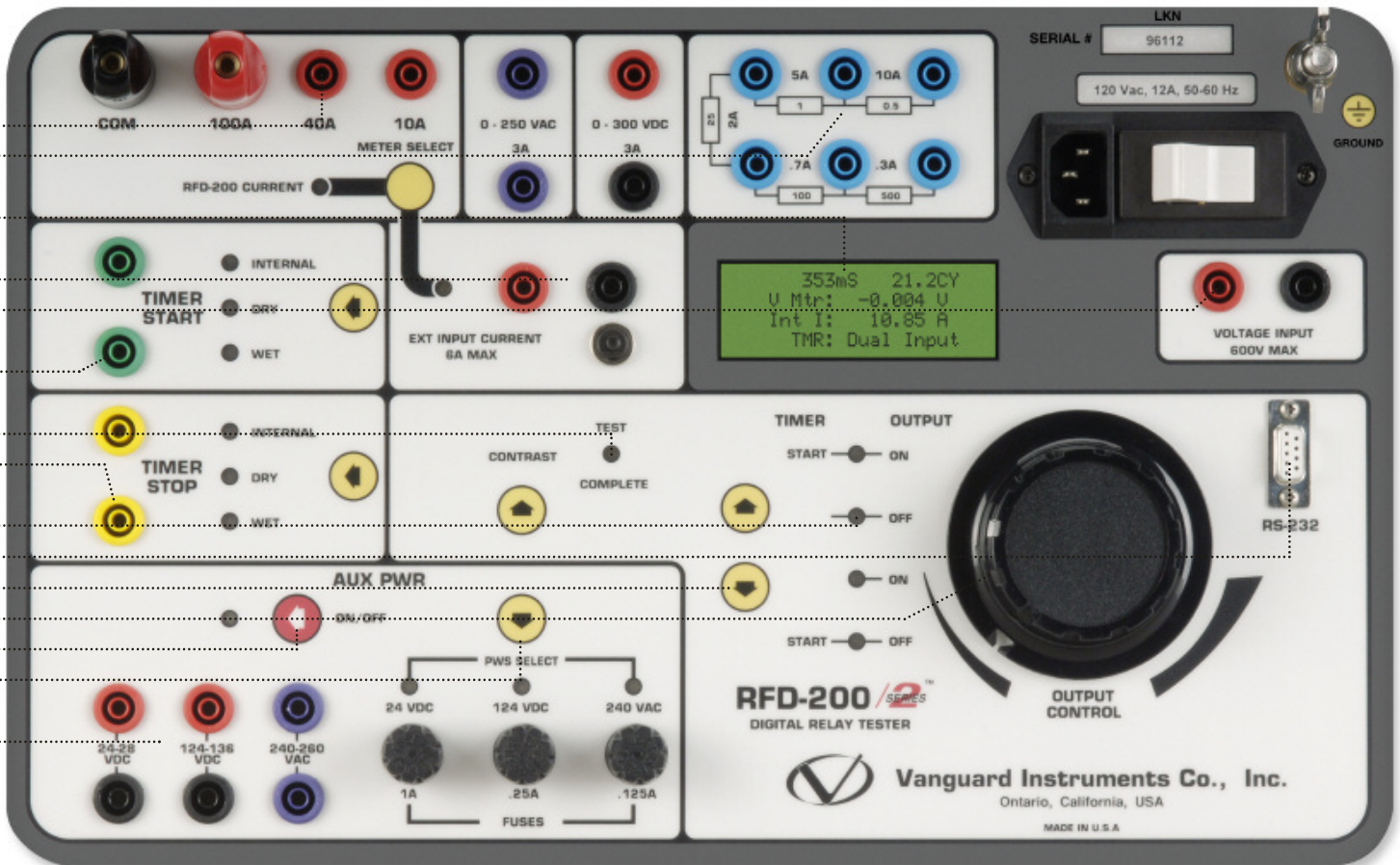

RFD-200 Series 2 Control Panel Description

1. Outputs

Current output: 0 – 250A AC. Voltage outputs: 0 – 250 Vac or 0 – 300 Vdc. Only one output is active at any one time. The output is set by the RFD-200 S2's Output Control Knob. The Current source output is controlled by a START/STOP switch and can be programmed to work with the timer.

2. External Input Current

Range: 0.000 – 6.000 A. This input is protected by a 10-Ampere circuit breaker.

3. Built-in Power Resistor

Built-in power resistor provides fine current regulation.

4. Voltage Input

External input volt meter range is 0.00 – 600.0V true RMS for AC and DC voltages.

5. RS-232C Interface

RS-232C port is used for factory calibration and diagnostics.

6. Output Control Knob

The Output Control Knob sets the voltage or current levels.

7. Auxiliary Power On/Off

This switch turns the auxiliary power source on or off.

8. Auxiliary Power Selector

Selects 24 Vdc, 124 Vdc or 240 Vac auxiliary power.

9. Test Complete LED

This LED flashes when a timing event is completed.

10. Control Mode Selection

This switch selects the RFD-200 S2's output.

11. Control Mode LED

Four control modes can be selected for the current source:

- "START-ON" – Output is turned on and timer starts.
- "OFF" – Current and Voltage sources are turned off.
- "ON" – Current and Voltage sources are turned on.
- "START-OFF" – Output is turned off and timer starts.

12. Auxiliary Power Connectors

Auxiliary AC/DC power supplies: Used to power solid-state/microprocessor-based relays.
Auxiliary power connectors for 24 Vdc, 124 Vdc, 240 Vac.

13. Timer Stop Input

The timer can be stopped with an internal trigger when the current source is turned on or off, or by a change in state of the dry-contact input, or by a change in state of the voltage input.

14. Timer Start

The timer can be stopped with the internal trigger when the current source is turned on or off, or by a change in state of the dry contact input, or by a change in state of the voltage input.

Vanguard Instruments Company, Inc.

Vanguard Instruments Co., (VIC), was founded in 1991. Currently, our 28,000 square-foot facility houses Administration, Design & Engineering, and Manufacturing operations. From its inception, VIC's vision was, and is to develop and manufacture innovative test equipment for use in testing substation EHV circuit breakers and other electrical apparatus.

The first VIC product was a computerized circuit-breaker analyzer, which was a resounding success. It became the forerunner of an entire series of circuit-breaker test equipment. Since its beginning, VIC's product line has expanded to include microcomputer-based, precision micro-ohmmeters, single and three-phase transformer winding turns-ratio testers, winding-resistance meters, transformer tap-changing controllers, megaohm resistance meters, and a variety of other electrical utility maintenance support products.

VIC's performance-oriented products are well suited for the utility industry. They are rugged, reliable, accurate, user friendly, and most are computer controlled. Computer control, with innovative programming, provides many automated testing functions. VIC's instruments eliminate tedious and time-consuming operations, while providing fast, complex, test-result calculations. Errors are reduced and the need to memorize long sequences of procedural steps is eliminated. Every VIC instrument is competitively priced and is covered by a liberal warranty.

Vanguard products are available from:



Vanguard Instruments Company, Inc.

1520 S. Hellman Ave. • Ontario, California 91761 USA • P 909-923-9390 • F 909-923-9391
www.vanguard-instruments.com